

# CAREER HEROES

A Career Awareness  
Workbook for Elementary Students



Office of Occupational and Labor Market Information  
Delaware Career Resource Network



November 2023

# **CAREER HEROES**

**A Career Awareness  
Workbook for Elementary Students**

**State of Delaware**  
John C. Carney, Governor

**Delaware Department of Labor**  
Karryl Hubbard, Secretary



***Adapted by:***

Delaware Department of Labor  
Office of Occupational and Labor Market Information (OOLMI)  
Delaware Career Resource Network

This publication was adapted from "Career Aware" by Oregon's Partnership for Occupational and Career Information and "Career Heroes" by the Montana Department of Labor and Industry. Activities in this publication are based on "Careers are Everywhere!" by Texas Workforce Solutions, Labor Market and Career Information, and "Career Heroes" by the Montana Department of Labor and Industry.

***Special thanks to:***

Robert Marvin, Montana Department of Labor and Industry, OOLMI Staff, and the Delaware Department of Labor

This publication is available for download at: <https://lmi.delaware.gov/Publications/>

Hard copies are available by request as funds allow.

Contact Kristie Manley at:

Delaware Department of Labor

Office of Occupational & Labor Market Information

19 West Lea Blvd.

Wilmington, DE 19802

(302) 761-8064

[kristie.manley@delaware.gov](mailto:kristie.manley@delaware.gov)

# Contents

<b>What is a Career Hero?-----</b>	<b>4</b>
<b>Realistic Careers for “Doers” -----</b>	<b>5</b>
<b>Investigative Careers for “Thinkers” -----</b>	<b>8</b>
<b>Artistic Careers for “Creators” -----</b>	<b>11</b>
<b>Social Careers for “Helpers” -----</b>	<b>14</b>
<b>Enterprising Careers for “Persuaders” -----</b>	<b>17</b>
<b>Conventional Careers for “Organizers” -----</b>	<b>20</b>
<b>Which Type Are You? -----</b>	<b>23</b>
<b>Additional Activities -----</b>	<b>24</b>

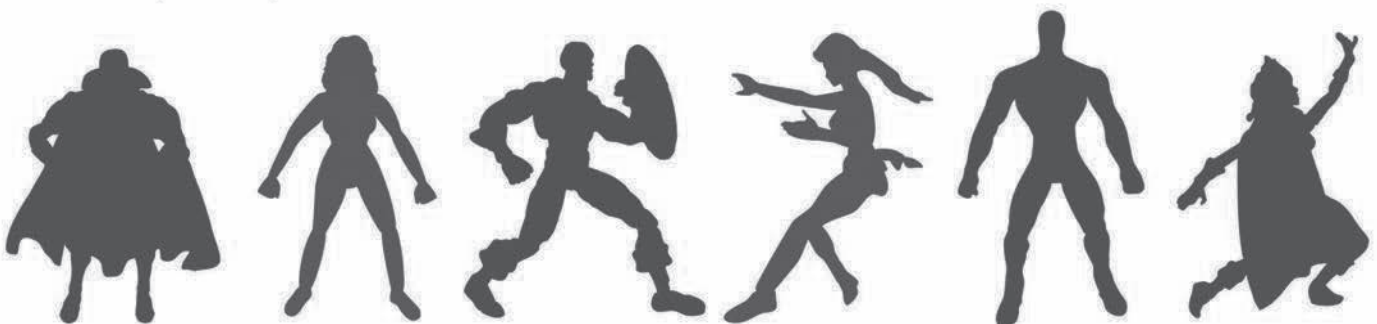

# ***WHAT IS A CAREER HERO?***

Have you ever noticed how average, ordinary workers are a lot like superheroes?

They might not wear spandex bodysuits (well, except for dancers and some athletes), but many do wear uniforms or distinctive clothing that marks them as someone who is there to help you.

Speaking of helping people, isn't that exactly what both superheroes and workers do all day long? Whether it's the man who paints your house or the lady who helps you get a loan to buy a house, people in careers are there to help you.

"But wait," you say, "Superheroes have special abilities. They have been through rigorous training, and have an arsenal of highly-specialized equipment to fight the forces of evil."

Exactly. And Career Heroes are no different. Performing each job takes a unique set of skills and knowledge. Some careers take years of training, and most require special tools that must be mastered.

In fact, we think Career Heroes are so special that they deserve their own set of trading cards. Each card features a different Career Hero and details the kinds of feats they perform on the job, the tools they have mastered, and the training they needed to qualify for their job.

This workbook introduces you to just a few of the hundreds of Career Heroes out there making the world a better place. It also describes the 6 different types of Career Heroes: Doers, Thinkers, Creators, Helpers, Persuaders, and Organizers. Maybe one of these types sounds a lot like you. Do you have what it takes to become a Career Hero?



# REALISTIC CAREERS

for "Doers"



People in **Realistic** careers like to work with things more than with people. They are usually good at doing things with their hands or playing sports. Most of the time, they like to be outdoors and work with tools and machines.

## Realistic Career Heroes Include:

- Automotive Mechanic
- Carpet Installers
- Etchers and Engravers
- Farmworkers
- Fish and Game Wardens
- Roofers

## CARPET INSTALLERS

Carpet Installers cut and lay carpet. They measure, clean, and check the floor, put down tack or tape, and lay the pad. Then they cut, lay, and stretch the carpet.

**Carpet Installer**

Wage Points: \$ 29/hour

**Feats Performed:**

*Carpet Installers* cut and lay carpet on floors. They measure the room, and figure out the size and shape they need for the pad and the carpet. They clean and fix the floor if needed, then cut the pad and carpet, lay them down and stretch the carpet to remove any bumps in it.

47-2041

## CAREER HERO CHALLENGE

In the space below, draw the shape that a piece of carpeting would need to be to fit your bedroom.

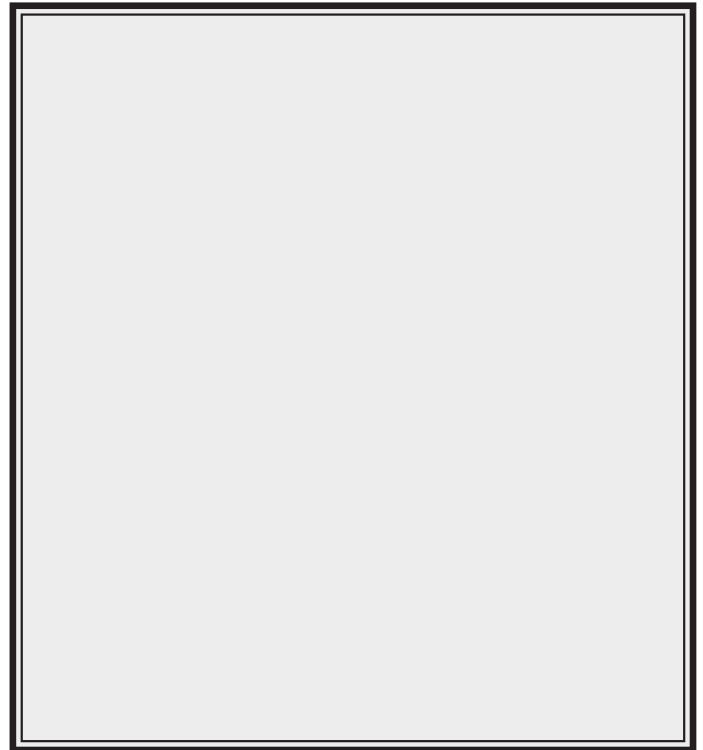



# REALISTIC CAREERS

for "Doers"

## AUTOMOTIVE MECHANIC

Automotive Mechanics repair automobiles, trucks, buses, and other vehicles. They talk to customers, test drive vehicles, and use diagnostic equipment to determine the problem. They also perform routine maintenance on vehicles.

### CAREER HERO CHALLENGE

List three businesses in your community where you would find an Automotive Mechanic.

1. \_\_\_\_\_
2. \_\_\_\_\_
3. \_\_\_\_\_



**Automotive Mechanic**

REALISTIC CAREER

Wage Points: \$ 24/hour

**Feats Performed:**

*Automotive Service Technicians & Mechanics* repair cars, trucks, buses, and other vehicles. They talk to customers, test drive vehicles, and use machines to figure out problems and fix them. They also do regular maintenance on vehicles, like oil changes.

49-3023

## FARMWORKERS, FARM AND RANCH ANIMALS

Farmworkers care for live farm, ranch, or aquacultural animals that may include cattle, sheep, swine, goats, horses and other equines, poultry, finfish, shellfish, and bees. They attend to animals produced for animal products, such as meat, fur, skins, feathers, eggs, milk, and honey.

### CAREER HERO CHALLENGE

Circle the animals that you think a Farmworker might care for.

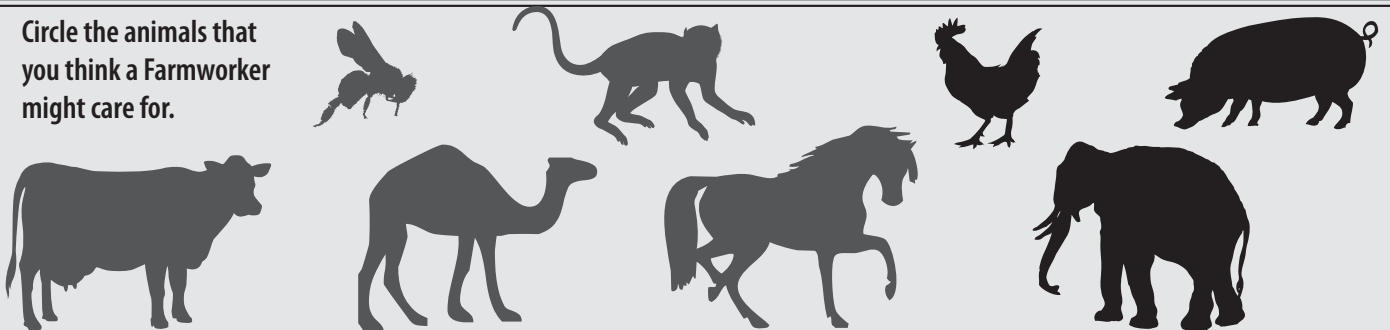

# REALISTIC CAREERS

for "Doers"



## ROOFERS

Roofers put roofs on new buildings. They repair or replace damaged roofs. They work on flat or slanted roofs. Sometimes they work on top of really tall buildings. Roofers also work with many types of materials.

### CAREER HERO CHALLENGE

In the space below, draw a type of building a roofer might work on. Give your building a label.

## ETCHERS & ENGRAVERS

Etchers and Engravers put letters or designs on things. They put designs on different types of metals. They can put pictures on wood pieces. They can also put letters on jewelry.

### CAREER HERO CHALLENGE

Pretend you've won first place in a competition of some kind. Write your name, and date, and the type of award on the trophy below.



## FISH AND GAME WARDENS

Fish and Game Wardens patrol assigned areas to prevent fish and game law violations. They investigate reports of damage to crops or property by wildlife. They also gather biological data.

### CAREER HERO CHALLENGE

Name an area near where you live that may have a Fish and Game Warden assigned to protect it.

**DOERS**

What other careers can you think of that might be in the Realistic group?

---

---



# INVESTIGATIVE CAREERS for "Thinkers"

People in Investigative careers like to explore and understand things or events, rather than persuade others or sell them things. They are usually good at math and science and like to work alone to solve problems.

## Investigative Career Heroes Include:

- Computer Systems Analysts
- Dieticians & Nutritionists
- Forensic Science Technicians
- Internists, General
- Soil & Plant Scientists
- Veterinarians

## NUTRITIONISTS

Nutritionists study how our bodies use the foods we eat. They help people choose foods that will keep their bodies healthy. They teach people about the basic food groups, vitamins, minerals, fats, and fiber. They plan menus for patients in hospitals or for cafeterias in places like schools and nursing homes.

INVESTIGATIVE CAREER



**Nutritionist**

**Wage Points:** \$ 34/hour

**Feats Performed:**

*Nutritionists* study how our bodies use the foods we eat. They help people choose foods that will keep their bodies healthy and strong. They teach people about basic food groups. They plan menus for schools, hospitals, and cafeterias.

29-1031

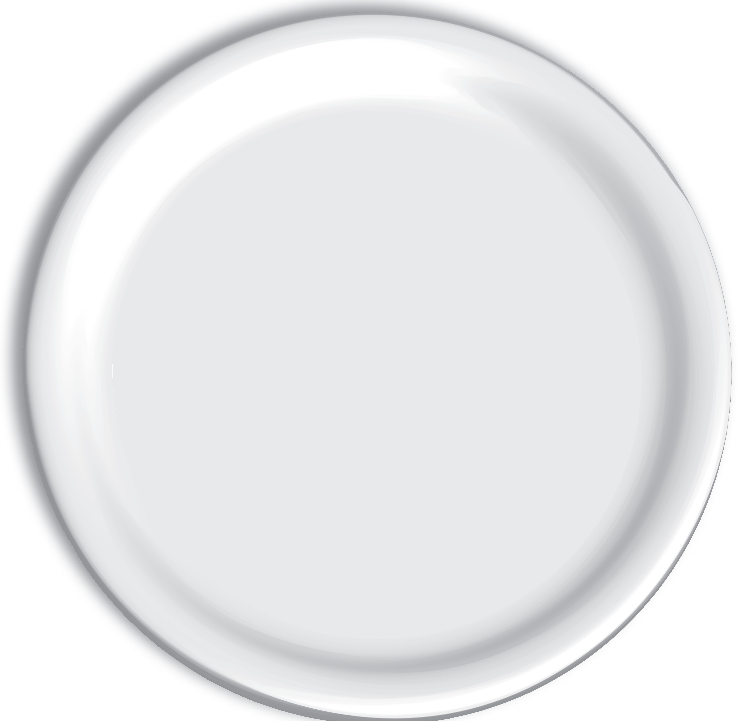

## CAREER HERO CHALLENGE

On the plate to the right, draw a healthy meal. Make sure to choose foods from different food groups.



# INVESTIGATIVE CAREERS

for "Thinkers"



## COMPUTER SYSTEMS ANALYSTS

Computer Systems Analysts design and plan ways that computers can do work for businesses and people. They study the kinds of work to be done, then they find or make computer equipment and software that can do the job. They test the finished system to make sure it works correctly.

### CAREER HERO CHALLENGE

See if you can list three things that computers can do for people that used to have to be done by hand.

1. \_\_\_\_\_
2. \_\_\_\_\_
3. \_\_\_\_\_

## SOIL AND PLANT SCIENTISTS

Soil and Plant Scientists research plants to see in what conditions they thrive. They may work with agricultural plants, studying what makes up the soil, and also how plants grow in different soils.

### CAREER HERO CHALLENGE

On the upper leaves of the plant, write in three kinds of plants. On the lower leaves, write in four things that people make from plants.



## INTERNISTS, GENERAL

Internists diagnose and provide non-surgical treatment of diseases and injuries of internal organ systems. They provide care mainly for adults who have a wide range of problems associated with the internal organs.

### CAREER HERO CHALLENGE

On the blank lines below each picture, write the name of the body organ.



\_\_\_\_\_

\_\_\_\_\_



\_\_\_\_\_

\_\_\_\_\_

\_\_\_\_\_



# INVESTIGATIVE CAREERS for "Thinkers"

**Veterinarian**

INVESTIGATIVE CAREER

Wage Points: \$56/hour

**Feats Performed:**

*Veterinarians* diagnose and treat animals with diseases or injuries. They help both pets and farm animals. They may also do research to help find better treatments, and advise pet owners and farmers how to care for their animals.

29-1131

## VETERINARIAN

Veterinarians diagnose and treat animals with diseases or injuries. They help both pets and farm animals. They may also do research to help find better treatments, and advise pet owners and farmers how to care for their animals.

### CAREER HERO CHALLENGE

Draw a picture of a pet that you have or would like to have.

## FORENSIC SCIENCE TECHNICIANS

Forensic Science Technicians help police investigate crimes. They collect, identify, and analyze evidence from crime scenes. They may specialize in areas like fingerprinting or handwriting.

### CAREER HERO CHALLENGE

**EVIDENCE**

Can you identify the fingerprint that matches the one in the evidence box? Remember, the position of the fingerprint on the evidence may be different than its position when taken directly from the finger.

# ARTISTIC CAREERS

for "Creators"

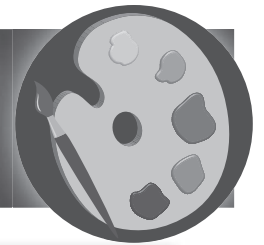

People in Artistic careers like to work with creative ideas and express themselves rather than working within routines and rules. They usually are good in art, enjoy creating their own art work, and have a good imagination.

## Artistic Career Heroes Include:

- Fine Artists
- Floral Designers
- Graphic Designers
- Interior Designers
- Photographers
- Poets, Lyricists & Creative Writers

## GRAPHIC DESIGNERS

Graphic Designers make things look good so people will be interested in them. Some design book, magazine, and CD covers. Graphic Designers may work on packages for products or pages on websites. Some of them create new wallpaper patterns, or design greeting cards.

### CAREER HERO CHALLENGE

Find a package for a product that a graphic designer probably created—something that looks good to you. List four reasons why you like the way it looks.

1. \_\_\_\_\_
2. \_\_\_\_\_
3. \_\_\_\_\_
4. \_\_\_\_\_

**Graphic Designer**

ARTISTIC CAREER

Wage Points: \$29/hour

**Feats Performed:**

*Graphic Designers* make things look good so people will like them. They create pictures and designs used on posters, books, and magazines. They also create images for product packages, T-shirts and websites. They create images by drawing, painting, or using a computer.

27-1024

**CREATORS**

What other careers can you think of that might be in the Artistic group?

\_\_\_\_\_

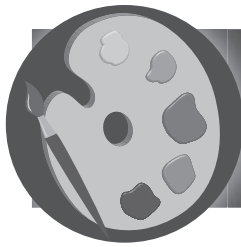

# ARTISTIC CAREERS

for "Creators"

## PHOTOGRAPHERS

Photographers produce and preserve images that paint a picture, tell a story, or record an event. They may take pictures of people, subjects, merchandise, or other commercial products. They may work in a studio or on location.



**Photographer**

ARTISTIC CAREER

Wage Points: \$ 20/hour

**Feats Performed:**

*Photographers* take pictures of people, places, and things. They might work in a studio and have people come to them, or they might go out and take pictures of people and places where they are. Some photographers take action pictures for the news, and others compose a picture like art.

27-4021

## CAREER HERO CHALLENGE

Photographers work with both objects and people. Find the words listed below in the word search puzzle.

BRIDE	FRAME	SHUTTER
CAMERA	IMAGE	SMILE
DIGITAL	LIGHT	STUDIO
FILM	SCAN	TRIPOD

F	A	R	E	M	A	C	M	T	J
V	M	T	E	S	M	I	L	E	X
R	D	L	A	T	I	G	I	D	V
C	J	L	H	U	T	T	F	U	U
S	G	G	Z	D	R	U	Q	C	N
J	I	B	R	I	D	E	H	S	H
L	W	C	P	O	M	M	C	S	C
W	D	O	X	H	O	A	L	F	B
R	D	C	D	Q	N	R	G	Y	N
Q	D	S	U	L	C	F	V	E	P

## FLORAL DESIGNERS

Floral Designers trim flowers to make bouquets, sprays, and wreaths. They make up dish gardens and flower arrangements. They arrange flowers the way their customers want, using the colors and types of flowers they choose.

## CAREER HERO CHALLENGE

List 3 events for which you might hire a Floral Designer.

1. \_\_\_\_\_
2. \_\_\_\_\_
3. \_\_\_\_\_

# ARTISTIC CAREERS

for "Creators"

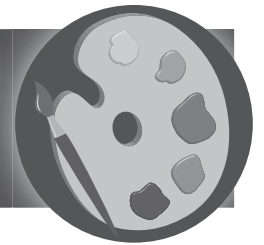

## FINE ARTISTS

Fine Artists draw and paint or create other artwork like sculptures that express feelings and ideas. They use many kinds of materials. Some paint using oils or watercolors. Some draw using pencils or pen and ink. Others mold or carve things out of rock, plaster, clay, or wood.

## CAREER HERO CHALLENGE

List 3 places where the work of Fine Artists is displayed.

1. \_\_\_\_\_
2. \_\_\_\_\_
3. \_\_\_\_\_

## POETS, LYRICISTS AND CREATIVE WRITERS

Poets, Lyricists and Creative Writers create original written works, such as scripts, essays, poetry or song lyrics, for publication or performance.

## CAREER HERO CHALLENGE

List your favorites.

BOOK	AUTHOR
POEM	POET
SONG	LYRICIST
MOVIE	SCREENWRITER

## INTERIOR DESIGNERS

Interior Designers plan and furnish the interiors of buildings. They find out what people like, how much money can be spent, and the purpose of the space (office, home, etc.) Then they decorate the area so it makes good use of space, is comfortable, and looks nice.

## CAREER HERO CHALLENGE

If you were an Interior Designer, what would your dream bedroom look like? Draw a sketch below.

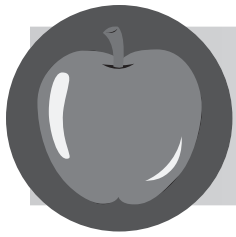

# SOCIAL CAREERS for "Helpers"

People in Social careers like to help, teach, and give people advice more than they like to work with things. They like to be around other people, are interested in how people get along, and like to help other people with their problems.

## Social Career Heroes Include:

- Child Care Workers
- Emergency Medical Technicians
- Fitness Trainers
- Medical Assistants
- School Counselors
- Training Specialists

## EMERGENCY MEDICAL TECHNICIANS

Emergency Medical Technicians, or EMTs, provide emergency medical care at the scene of an accident or in people's homes after someone calls 911. EMTs find out the patient's condition and decide the immediate treatment needed. They give emergency care following strict rules. When needed, they transport the patient to a hospital for further treatment.

SOCIAL CAREER



**Emergency Medical Technician**

Wage Points: \$ 20/hour

**Feats Performed:**

*Emergency Medical Technicians (EMTs)* help people at the scene of an accident or in people's homes after someone calls 911. They check the patient's condition and decide what treatment is needed right there. If needed, they can take the patient to a hospital.

29-2042

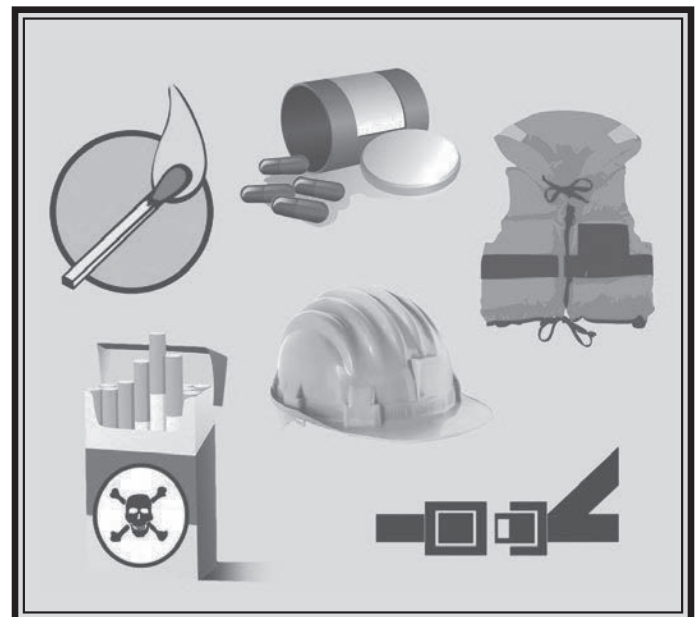

## CAREER HERO CHALLENGE

In the box to the right, circle the things that could *prevent* an accident. Then, cross out the items that could *cause* an accident or health problem.

# SOCIAL CAREERS

for "Helpers"

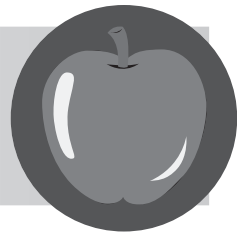

## FITNESS TRAINERS

Fitness Trainers help people set and reach goals to improve their fitness. They determine their client's physical condition, then suggest exercises that will most help this person. Fitness trainers also show the person how to do the exercise safely and for the best results. They may keep records of their clients' exercise sessions in order to help them make progress toward physical fitness. Some fitness trainers lead exercise classes, such as aerobics.

## CHILD CARE WORKERS

Child Care Workers attend to children at businesses, schools, and private households. They may dress, feed, bathe, and play with children. The children they tend may be infants, toddlers, or school age children.

### CAREER HERO CHALLENGE

Child Care Workers may spend time with children of all ages. Next to each age group below, list an activity that you think would be appropriate for that age group.

Infants:

Toddlers:

School-age children:



**Fitness Trainer**

SOCIAL CAREER

Wage Points: \$22/hour

**Feats Performed:**

*Fitness Trainers* help people set and reach fitness goals. They teach people exercises and show them how to do them properly. They teach new exercises to help people keep improving. They sometimes lead classes in doing exercises together.

39-9031

### CAREER HERO CHALLENGE

What's your favorite way to exercise? Show us what you look like when you exercise.

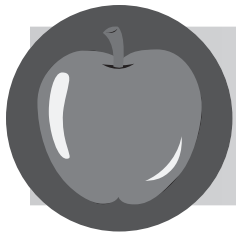

# SOCIAL CAREERS for "Helpers"

## TRAINING SPECIALISTS

Training Specialists manage and carry out training and development programs for employees. They study how adults learn and help workers gain skills to make them better at their jobs.

### CAREER HERO CHALLENGE

List 4 things you're good at that you could teach others to do.

1. \_\_\_\_\_
2. \_\_\_\_\_
3. \_\_\_\_\_
4. \_\_\_\_\_

## SCHOOL COUNSELORS

School Counselors help evaluate students' abilities, interests, and talents to set goals for school, work, and life. They work with individuals and with groups of students. They also work with teachers to help classroom activities meet children's needs.

### CAREER HERO CHALLENGE

Name three skills that School Counselors should have to do their job well.

1. \_\_\_\_\_
2. \_\_\_\_\_
3. \_\_\_\_\_

## MEDICAL ASSISTANTS

Medical Assistants help keep the offices of doctors and other health care providers running smoothly. They may answer telephones, greet patients, update and file medical records, and fill out insurance forms. They may also schedule appointments and handle billing. Some medical assistants may ask patients about their medical histories and record vital signs like heart rate, blood pressure, and body weight. They may also prepare patients for examination and help doctors during the exam.

### CAREER HERO CHALLENGE

Circle the tools or supplies a Medical Assistant might use in a doctor's office.

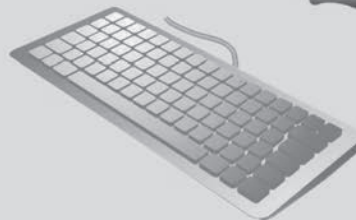



# ENTERPRISING CAREERS

for "Persuaders"



People in Enterprising careers like to persuade others to do things or give them directions to follow rather than working with things or ideas. They usually like to be a group leader.

## Enterprising Career Heroes Include:

- 🏠 Chefs
- 🏠 Chief Executives
- 🏠 Flight Attendants
- 🏠 Judges
- 🏠 Telemarketers
- 🏠 Travel Agents

## CHEFS

Chefs plan menus for restaurants, often inventing their own unique recipes. Chefs supervise the activities of the other cooks and food preparation workers, order food and supplies, estimate the costs of the ingredients, and determine how the food should be presented. They may also participate in cooking.



**Chef**

ENTERPRISING CAREER

Wage Points: \$ 30/hour

Feats Performed:

*Chefs* plan menus and create new dishes and food combinations. They supervise other chefs and kitchen workers. They figure out the costs of food, and place orders for food and other supplies. They also make sure the food is cooked properly and looks nice.

35-1011

## CAREER HERO CHALLENGE

List the menu for your favorite holiday meal.

## PERSUADERS

What two careers can you think of that might be in the Enterprising group?

---

---



# ENTERPRISING CAREERS

for "Persuaders"

## TRAVEL AGENTS

Travel Agents plan entire trips for clients. They plan the places to go and things to do. They make lodging, transportation, and entertainment reservations. Travel Agents may plan trips for individuals, businesses, or large groups of people.



**Travel Agent**

ENTERPRISING CAREER

Wage Points: \$ 20/hour

**Feats Performed:**

*Travel Agents* help people plan trips and vacations. They help them decide where to go and what to do when they get there. They research costs of travel and places to stay, then they make reservations and can arrange tours.

41-3041

### CAREER HERO CHALLENGE

Look at a map or globe and choose a place you would like to visit. Then plan a trip to that place, thinking about how you would get there, how long it may take, and things you could see and do when you get there. Write a report.

## TELEMARKETERS

Telemarketers contact people and businesses by phone to sell them things. They explain the product or service, talk to the customer about what they need, and take orders and customer information over the phone.

### CAREER HERO CHALLENGE

List three items that Telemarketers sell to people over the phone.

1. \_\_\_\_\_
2. \_\_\_\_\_
3. \_\_\_\_\_

## FLIGHT ATTENDANTS

Flight Attendants provide personal services to ensure the safety and comfort of airline passengers during flight. They greet passengers, verify tickets, explain use of safety equipment, and serve food and beverages.

### CAREER HERO CHALLENGE

Have you ever flown on an airplane? List 4 things you might see from your airplane window.

1. \_\_\_\_\_
2. \_\_\_\_\_
3. \_\_\_\_\_
4. \_\_\_\_\_

# ENTERPRISING CAREERS

for "Persuaders"



## CHIEF EXECUTIVES

Chief Executives (also called CEOs) run companies or organizations. They make decisions about company policies and the overall direction their business should take. They plan company budgets, coordinate departments, and negotiate deals and contracts with other businesses. They are the highest level of company management.

### CAREER HERO CHALLENGE

Think about some large businesses in Delaware. Can you name 2 that probably have a Chief Executive?

1. \_\_\_\_\_ 2. \_\_\_\_\_

## JUDGES

Judges apply the law and oversee the legal process in courts according to local, state, and federal statutes. They preside over cases concerning every aspect of society from traffic offenses to disputes over the management of professional sports to issues concerning the rights of huge corporations. The court must safeguard the legal rights of all parties involved.

### CAREER HERO CHALLENGE

Have you ever been in a courtroom or seen one on TV? Who would you find in a courtroom? What kind of furniture and objects are in a courtroom? Draw a picture of a courtroom and label the people and objects in your drawing.



# CONVENTIONAL CAREERS

## for "Organizers"

People in Conventional careers like to follow orders and do things exactly according to directions. They usually don't like work that does not have clear instructions to follow. They are usually good in math, like to organize their things, and like to work indoors.

### Conventional Career Heroes Include:

- Compliance Officers
- Loan Officers
- Cashiers
- Mail Carriers
- Librarians
- Bank Tellers

## CASHIER

Cashiers receive money as payment for goods or services. They give back change when it is due. They may also take credit cards as a form of payment. They can use scanners, cash registers or other equipment. Cashiers also greet customers entering stores and assist customers by providing information and resolving their complaints.

CONVENTIONAL CAREER



**Wage Points: \$13/hour**

**Feats Performed:**

*Cashiers* receive money as payment for goods or services. They give back change when it is due. They may also take credit cards as a form of payment. They can use scanners, cash registers or other equipment.

### CAREER HERO CHALLENGE

Think about the last time you went into a store and a cashier spoke to you, then answer the questions below.

1. Did a cashier greet you in a friendly way? \_\_\_\_\_
2. What did he/she say to you? \_\_\_\_\_  
\_\_\_\_\_
3. How did that make you feel? \_\_\_\_\_  
\_\_\_\_\_
4. Did you need to ask for assistance at any time while you were in the store? \_\_\_\_\_
5. Was the cashier knowledgeable and able to answer your question or help you find what you needed? \_\_\_\_\_  
\_\_\_\_\_  
\_\_\_\_\_

# CONVENTIONAL CAREERS

for "Organizers"



## MAIL CARRIER

Mail Carriers sort mail for delivery. They deliver mail to residences and businesses along specified routes by walking or driving. They use a combination of satchels, carts, cars, and small trucks. They also deliver packages. When they finish their route, they return to the post office with mail they have collected from the homes, businesses, and public mailboxes.

**Mail Carrier**

CONVENTIONAL CAREER

Wage Points: \$ 27/hour

**Feats Performed:**

*Mail Carriers* sort mail for delivery. They deliver mail on an established route either by vehicle or on foot. They also deliver packages. When they finish their route, they return to the post office with mail collected from homes, businesses, and public mailboxes.

43-5052

## CAREER HERO CHALLENGE

Unscramble the following mail words.

amli krtcu \_\_\_\_\_

spto fiofec \_\_\_\_\_

nleepveo \_\_\_\_\_

caeagkp \_\_\_\_\_

psatm \_\_\_\_\_

ieldyrev \_\_\_\_\_

riatonifnom \_\_\_\_\_

oerut \_\_\_\_\_

omlxabi \_\_\_\_\_

edabcro \_\_\_\_\_

## BANK TELLERS

Bank Tellers work directly with the public in banks and other financial workplaces. They cash checks, accept deposits and loan payments, and help customers withdraw money from their accounts. They may also sell savings bonds and traveller's checks, accept payments for customers' utility bills, and process paperwork.

## CAREER HERO CHALLENGE

Suppose you are a Bank Teller. A customer wants to cash a check for \$109.28 and withdraw \$74.97 in cash from her savings account. How much total cash will she get?



# CONVENTIONAL CAREERS for "Organizers"

## LIBRARIANS

Librarians work in a variety of settings including public libraries, schools, museums, law firms, corporations, and non-profit and government agencies. They select, acquire, catalogue, circulate, and maintain library materials. They perform research and work with databases and information systems. They often teach customers how to use library resources.

### CAREER HERO CHALLENGE

1. Put a check mark to the <i>left</i> of the characteristics that are important for a Librarian to have.	<input type="checkbox"/>	Well-mannered	<input type="checkbox"/>
	<input type="checkbox"/>	Helpful	<input type="checkbox"/>
	<input type="checkbox"/>	Good Listener	<input type="checkbox"/>
	<input type="checkbox"/>	Athletic	<input type="checkbox"/>
2. Put a check mark to the <i>right</i> for each characteristic that you have.	<input type="checkbox"/>	Organized	<input type="checkbox"/>
	<input type="checkbox"/>	Strong math skills	<input type="checkbox"/>
	<input type="checkbox"/>	Like to be outside	<input type="checkbox"/>

## LOAN OFFICERS

Loan Officers determine whether or not a bank can lend money to specific borrowers. Officers meet with loan applicants to answer their questions, to explain the different types of loans that are available, and to work out the terms and conditions for paying off the loan. They review loan applications and research the credit history of the applicants.

### CAREER HERO CHALLENGE

Suppose a friend wants to borrow money from you. What questions would you ask your friend to help you decide whether you would loan the money or not?

## COMPLIANCE OFFICERS

Compliance Officers examine permits, licenses, applications, and records to ensure that people comply with licensing requirements. They determine the nature of code violations, write violation notices, and participate in enforcement hearings. Compliance Officers prepare, organize, and maintain inspection records. They monitor follow-up actions where violations were found.

### ORGANIZERS

*What other careers can you think of that might be in the Conventional group?*

---



---



---

# WHICH TYPE ARE YOU?

Here's a list of the six Career Types and the things people in those career types like to do. Under each one, circle the items that you also like to do.



## Realistic

I like to...

- work with things.
- play sports.
- use tools and machines.
- be outdoors.

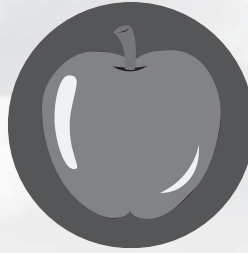

## Social

I like to...

- help people.
- teach others.
- give advice.
- be around people.



## Investigative

I like to...

- solve problems.
- explore.
- learn new things.
- use math and science.



## Enterprising

I like to...

- persuade others.
- give directions.
- work with people.
- be a leader.



## Artistic

I like to...

- express myself.
- do art projects.
- create things.
- use my imagination.



## Conventional

I like to...

- follow instructions.
- solve math problems.
- organize things.
- work indoors.

Which one of the 6 Career Types do you think fits you best? On the lines below, explain why you think this type would be a good fit for you.

---

---

---

No matter which career type you choose, the additional activities in the rest of this workbook will help you learn more about the world of careers.



# ADDITIONAL ACTIVITIES

## TRUE/FALSE QUIZ

Check the boxes to indicate whether each statement is true or false. On the blank lines, write why you chose true or false.

- |   | True                     | False                    |
|---|--------------------------|--------------------------|
| 1. I need to know exactly what I want to be when I grow up.<br>_____                          | <input type="checkbox"/> | <input type="checkbox"/> |
| 2. Once I decide on a career, I have to stay in that career for the rest of my life.<br>_____ | <input type="checkbox"/> | <input type="checkbox"/> |
| 3. My job right now is being a student in school.<br>_____                                    | <input type="checkbox"/> | <input type="checkbox"/> |
| 4. Lots of good work habits begin when I am a student.<br>_____                               | <input type="checkbox"/> | <input type="checkbox"/> |
| 5. Kids my age don't have jobs.<br>_____  | <input type="checkbox"/> | <input type="checkbox"/> |
| 6. The only place we learn things is in school.<br>_____                                      | <input type="checkbox"/> | <input type="checkbox"/> |
| 7. Working in a group is easy because everyone always agrees with one another.<br>_____       | <input type="checkbox"/> | <input type="checkbox"/> |
| 8. People get hired for jobs just because they want them.<br>_____                            | <input type="checkbox"/> | <input type="checkbox"/> |
| 9. I need information to make good choices.<br>_____  | <input type="checkbox"/> | <input type="checkbox"/> |
| 10. Positive thinking helps me take action; negative thinking causes me to stop.<br>_____     | <input type="checkbox"/> | <input type="checkbox"/> |
| 11. I can learn from my mistakes.<br>_____  | <input type="checkbox"/> | <input type="checkbox"/> |
| 12. It is important for me to have a plan of action when I decide on a career.<br>_____       | <input type="checkbox"/> | <input type="checkbox"/> |





## DEFINITIONS

**Employer:** The person or company who pays a worker for doing a job.

**Industry:** A group of businesses providing similar types of goods or services.

**Job:** The set of tasks done for a specific employer.

**Occupation:** The name for a unique set of tasks, skills, and abilities that a worker performs. People who work for different employers can still be in the same occupation.

**Skills:** Abilities that you have gained through training and practice. They may not be the things you are “naturally” good at, but rather the things you have worked hard to be good at.

### Questions:

1. What **occupations** do your family members or family friends have?

---

---

---

---

2. What are the names of some of the **employers** in your community?

---

---

---

---

3. What kinds of **jobs** can be done in a hospital?

---

---

---

---



## ***WRITE IT DOWN***

How many occupations can you list that begin with the letter...

**P** \_\_\_\_\_  
\_\_\_\_\_  
\_\_\_\_\_

**S** \_\_\_\_\_  
\_\_\_\_\_  
\_\_\_\_\_

**B** \_\_\_\_\_  
\_\_\_\_\_  
\_\_\_\_\_

**C** \_\_\_\_\_  
\_\_\_\_\_  
\_\_\_\_\_

**T** \_\_\_\_\_  
\_\_\_\_\_  
\_\_\_\_\_

**M** \_\_\_\_\_  
\_\_\_\_\_  
\_\_\_\_\_



# WORD SEARCH

Find the hidden words listed below. Remember, the words can run up, down, backward, forward, or diagonally.

**Word List:**

Career	Industry	Explore	Profession	Training
Work	Employer	Business	Occupation	Labor Market
Job	Wage	Goal	Skill	Employment
Tools	Salary	Uniform	Interests	Information

C	H	U	S	T	S	E	R	E	T	N	I	L	O
A	V	C	K	T	R	A	I	N	I	N	G	C	O
R	D	V	I	N	D	U	S	T	R	Y	C	P	E
E	M	P	L	O	Y	M	E	N	T	U	F	W	D
E	C	I	L	R	G	M	K	R	P	Q	S	A	N
R	W	T	A	E	P	S	E	A	G	O	M	G	N
J	U	L	S	L	O	O	T	J	N	X	O	E	J
Q	A	X	O	F	Z	I	D	O	C	A	I	O	L
S	B	Y	A	H	O	P	I	B	L	F	W	K	M
Y	E	R	E	N	B	S	Y	S	H	G	D	W	R
R	M	Q	B	S	S	E	N	I	S	U	B	K	O
Z	L	I	F	E	X	P	L	O	R	E	J	J	F
S	G	A	F	V	N	M	N	O	C	U	X	W	I
R	I	O	I	N	F	O	R	M	A	T	I	O	N
A	R	Z	T	M	H	T	P	K	Y	L	B	R	U
P	L	A	B	O	R	M	A	R	K	E	T	K	A



# CAREER HERO SECRET IDENTITY SCRAMBLE

Can you reveal the secret identities of the career heroes by unscrambling the letters in the list of names below?

- 1) **Anna C. Coutt** \_\_\_\_\_
- 2) **Ray Creets** \_\_\_\_\_
- 3) **Tim Niser** \_\_\_\_\_
- 4) **Roy Tenat** \_\_\_\_\_
- 5) **Art Rein** \_\_\_\_\_
- 6) **Chet Incani** \_\_\_\_\_
- 7) **Leon Roucs** \_\_\_\_\_
- 8) **Nat Joir** \_\_\_\_\_
- 9) **Sami C. Thin** \_\_\_\_\_
- 10) **Regie Nen** \_\_\_\_\_
- 11) **Lela A. Prag** \_\_\_\_\_
- 12) **Vic E. Teedt** \_\_\_\_\_
- 13) **Bee W. Smart** \_\_\_\_\_
- 14) **Chet Ear** \_\_\_\_\_

## **Words to choose from:**

Minister	Engineer	Janitor	Trainer	Teacher
Detective	Accountant	Secretary	Webmaster	Machinist
Technician	Counselor	Paralegal	Attorney	



# EQUIPMENT CHALLENGE

Career Heroes have all the skills, knowledge, and training they need to be experts at their jobs. However, without the right tools, they can't do their jobs at all.

1. Matching - Draw a line connecting the careers on the top with the correct tools on the bottom.

**Astronomer**      **EXTERMINATOR**      **Physician**

**BIOLOGIST**      *Medical Records Technician*      **REALTOR**

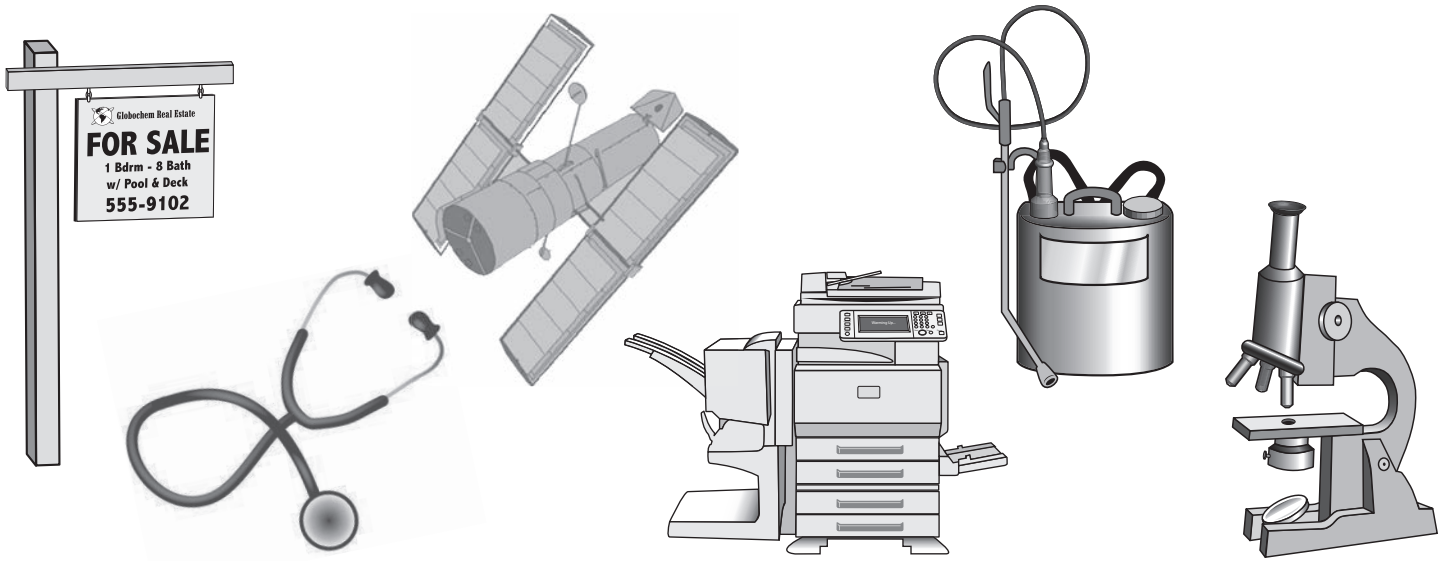

2. Drawing - In the boxes below, draw a picture of a tool that might be used by each Career Hero.

Carpenter	Police Officer	Teacher	Reporter



# FIREFIGHTER MAZE

Every occupation uses a unique set of tools. Help the Firefighter Career Hero collect his tools. Taking the route with the firefighter's tools will lead you to the fire.

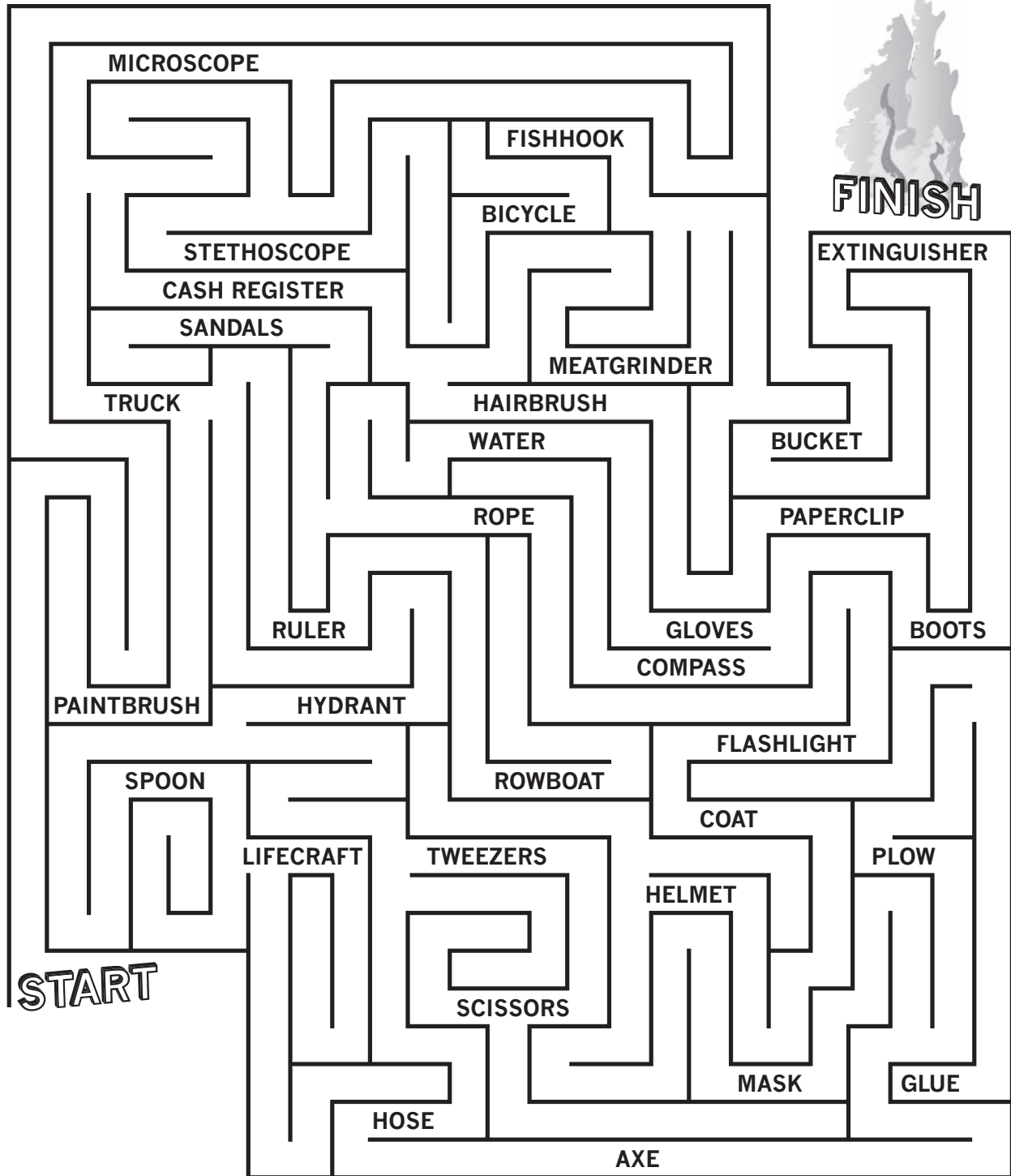



# **CHOOSE AN OCCUPATION**

1. Choose an occupation that interests you and write it down here:

---

2. What kind of skills do you think a person would need for this occupation?

---

---

---

3. What kind of technology or tools would a person in this occupation use?

---

---

---

4. What do you think a person in this occupation does on a typical day?

---

---

---

5. How is this person's day on the job similar to your day at school?

---

---

---

6. What kind of education do you think a person would need for this occupation?

---



# ***INTERVIEW***

One of the best ways to learn about a career is to interview someone working in that career. Interview a person in a career that interests you. Here are some questions you might want to ask.

1. Where do you work?

---

2. What is your job title?

---

3. What is your favorite part of the job?

---

4. What is your least favorite part of the job?

---

5. Have you ever made a mistake in your job? How did you handle it?

---

6. What is the easiest part of your job?

---

7. What is the hardest part of your job?

---

8. Do you use any special tools in your job?

---

9. Did you need special training for your job?

---

10. How did you figure out what occupation you wanted to pursue?

---

11. What was your favorite subject in school?

---

12. What school subject helps you the most in your job?

---

13. What occupation did you think about when you were young?

---

14. What do you like to do in your free time?

---





# MULTIPLE ROLES

Every person plays more than one role in life. Can you identify some of your roles?

I am the child of \_\_\_\_\_.

I am the student of \_\_\_\_\_.

I live in the community of \_\_\_\_\_.

I am a member of \_\_\_\_\_.

I am a player of \_\_\_\_\_.

I am an owner of \_\_\_\_\_.

I am a relative of \_\_\_\_\_.

I am a friend of \_\_\_\_\_.

\_\_\_\_\_ is a teacher at my school.

\_\_\_\_\_ is a person in my neighborhood.

\_\_\_\_\_ is a member of my family.

\_\_\_\_\_ is a member of my team.

\_\_\_\_\_ is a member of my class.

## Self-knowledge

The more you know about yourself, the better you can pick a career that is right for you. Fill in the blanks below with information about yourself.

1. Things that interest me at home: \_\_\_\_\_

2. Things that interest me at school: \_\_\_\_\_

3. Things I am good at doing: \_\_\_\_\_

4. Subjects I have to work hard at: \_\_\_\_\_

5. Subjects that are easy for me: \_\_\_\_\_

6. I like to solve number problems. (circle one)  
yes no

7. I like to write about my ideas. yes no

8. I am very organized. yes no

9. What careers might use some of your interests and abilities? \_\_\_\_\_



# WORK HABITS

Good work habits are important in any job you have. Right now your job is going to school. Look at your work habits at school and at home and see where you could work to improve these habits for the future. From the following list of good habits, circle the number from 1 to 5 that best shows how often you practice these habits.

## School Work Habits:

	Never				Always
I arrive at school on time.	1	2	3	4	5
I listen to directions.	1	2	3	4	5
I hand in homework on time.	1	2	3	4	5
I cooperate with other students.	1	2	3	4	5
I check my work.	1	2	3	4	5
I work neatly.	1	2	3	4	5
I use my time wisely.	1	2	3	4	5
I keep my desk neat and clean.	1	2	3	4	5
I try to improve my grades.	1	2	3	4	5
I follow the rules.	1	2	3	4	5

## Home Work Habits:

	Never				Always
I wake up on time.	1	2	3	4	5
I listen to directions.	1	2	3	4	5
I do chores when I am supposed to.	1	2	3	4	5
I cooperate with my brothers and sisters.	1	2	3	4	5
I check that my chores are done completely.	1	2	3	4	5
I put my things away.	1	2	3	4	5
I use my time wisely.	1	2	3	4	5
I keep my room neat and clean.	1	2	3	4	5
I help without being asked.	1	2	3	4	5
I follow the rules.	1	2	3	4	5

Two habits I will try to improve are:

1. \_\_\_\_\_

2. \_\_\_\_\_



# **WORK ENVIRONMENT**

Different careers take place in different environments. A forest ranger works in a very different place than an elementary school teacher. Think about the environment in which you may want to work. On each line, circle the environment you like better.

**Would you like to...**

**or would you rather...**

- work indoors ..... work outdoors
- work with people..... work with information
- travel ..... work in an office
- work with your hands ..... work with your mind
- work by yourself ..... work in groups
- work during the day..... work at night
- work in busy places..... work in quiet places
- wear a uniform ..... wear everyday clothing
- make things ..... sell things
- communicate with words ..... use math
- work 12 months a year ..... work during certain seasons
- work the same schedule every day ..... work a changing schedule
- give directions to others ..... take directions from others
- work with humans..... work with animals
- work under pressure ..... work without deadlines

Can you think of three occupations in which you would work mostly in your favorite environment?  
Write the occupation and the environment that you like.

**Occupation**

**Environment**

---

---

---

---

---

---





## ***CAN YOU HAIKU?***

Haiku poems are unrhymed traditional Japanese poetry. They are very short, just 3 lines, with 17 syllables total. The first and third lines have 5 syllables and the second line has 7 syllables. Most Haiku poems describe some detail of everyday life with a personal reaction. The poems have two sections. The poet moves from description to reflection. Try to create an image of yourself or a career with just a few words following the Haiku format. Here are 3 examples to help you get started:

### **The Accountant:**

*Adding, subtracting  
Calculator on the desk  
Numbers never stop*

### **Susan:**

*A large broad smile  
Her wide open brown eyes blink  
Happy in her skin*

### **The Vet:**

*The animals come  
Each day the doors open wide—  
Owners look like them*

(5) \_\_\_\_\_

(7) \_\_\_\_\_

(5) \_\_\_\_\_

(5) \_\_\_\_\_

(7) \_\_\_\_\_

(5) \_\_\_\_\_

(5) \_\_\_\_\_

(7) \_\_\_\_\_

(5) \_\_\_\_\_



## ***WHAT KIND OF CAREER HERO ARE YOU?***

Now that you've met some Career Heroes and have learned lots about the different types of occupations out there, do you have an idea what type of Career Hero you would like to be? In the space below and on the following page, draw a picture of yourself as a Career Hero.

Wage Points: \$ \_\_\_/hour

**Feats Performed:**

Don't forget to list all the information associated with your chosen career. Go to your library or to [www.onetonline.org](http://www.onetonline.org) to find out anything you don't yet know about your occupation. And don't forget to have fun—right now, and in your future career!



## ***CAREER HEROES***

**Super Powers (Skills):**

**Mental Powers (Knowledge):**

**Tools Mastered:**

**Training:**

**Number of Heroes in this Career (Delaware):**

**Cluster**

# **CAREER HEROES**

**A Career Awareness  
Workbook for Elementary Students**



**Delaware Department of Labor**

Office of Occupational and Labor Market Information  
19 West Lea Blvd.  
Wilmington, DE 19802  
302-761-8064